

Euroclad Group Limited

Wentloog Corporate Park
Wentloog Road
Cardiff CF3 2ER

Tel: 02922 010101 Fax: 02922 010122

website: www.euroclad.com



Agrément Certificate

04/4151

Product Sheet 4

EUROCLAD ROOF SYSTEMS

EUROCLAD VIEO ROOF SYSTEMS

This Agrément Certificate Product Sheet⁽¹⁾ relates to Euroclad Vieo Roof Systems, comprising interlocking profiled aluminium or steel sheets that can be insulated with Euroclad RocSlab Insulation. The systems can be fixed to a continuous deck or other supporting structures capable of transferring variable and permanent load actions (fully supported) or timber battens (self-supported) on roofs with a finished pitch of 1° to 70° and curved installations with a minimum self-curve radius of 20 metres, where access is available only for maintenance or repair. The systems are suitable for use in residential and non-residential buildings such as schools, hospitals, industrial, commercial, retail and leisure applications.

(1) Hereinafter referred to as 'Certificate'.

CERTIFICATION INCLUDES:

- factors relating to compliance with Building Regulations where applicable
- factors relating to additional non-regulatory information where applicable
- independently verified technical specification
- assessment criteria and technical investigations
- design considerations
- installation guidance
- regular surveillance of production
- formal three-yearly review.

KEY FACTORS ASSESSED

Structural performance — the systems will remain structurally stable and deflections will not be excessive under normal service conditions if installed in accordance with the requirements of this Certificate (see section 6).

Weathertightness — the systems will resist the passage of rain and wind-driven snow when installed in accordance with the requirements of this Certificate (see section 7).

Thermal performance — roofs constructed using the systems can contribute to enabling a building to satisfy the requirements of the national Building Regulations (see section 8).

Condensation risk — the risk of condensation forming under normal service conditions is negligible (see section 9).

Performance in relation to fire — the profiled sheets have a notional designation/European class of AA/B_{ROOF} (t4) and the external sheets have a Class 0 or 'low risk' internal surface spread of flame classification (see section 11).

Durability — durability depends on the location, environment and finish coatings used (see section 14).



The BBA has awarded this Certificate to the company named above for the systems described herein. These systems have been assessed by the BBA as being fit for their intended use provided they are installed, used and maintained as set out in this Certificate.

On behalf of the British Board of Agrément

Paul Valentine
Technical Excellence Director

Claire Curtis-Thomas
Chief Executive

Date of Second issue: 14 February 2018

Originally certificated on 6 March 2012

Certificate amended on 20 December 2018 to update company name.

The BBA is a UKAS accredited certification body – Number 113.

The schedule of the current scope of accreditation for product certification is available in pdf format via the UKAS link on the BBA website at www.bbacerts.co.uk

Readers are advised to check the validity and latest issue number of this Agrément Certificate by either referring to the BBA website or contacting the BBA direct.

Any photographs are for illustrative purposes only, do not constitute advice and should not be relied upon.

British Board of Agrément

Bucknalls Lane
Watford
Herts WD25 9BA

©2018

Page 1 of 19

tel: 01923 665300
clientservices@bbacerts.co.uk
www.bbacerts.co.uk

Regulations

In the opinion of the BBA, Euroclad Vieo Roof Systems, if installed, used and maintained in accordance with this Certificate, can satisfy or contribute to satisfying the relevant requirements of the following Building Regulations (the presence of a UK map indicates that the subject is related to the Building Regulations in the region or regions of the UK depicted):



The Building Regulations 2010 (England and Wales) (as amended)

Requirement:	A1	Loading
Comment:		The systems will have sufficient strength and stiffness to sustain and transmit the design load in accordance with section 6 of this Certificate.
Requirement:	B4(2)	External fire spread
Comment:		The systems can satisfy this Requirement. See sections 11.1, 11.2 and 11.4 of this Certificate.
Requirement:	C2(b)	Resistance to moisture
Comment:		The systems can satisfy this Requirement. See section 7 of this Certificate.
Requirement:	C2(c)	Resistance to moisture
Comment:		The systems can contribute to minimising risk of surface and interstitial condensation. See sections 9.1 to 9.4 of this Certificate.
Requirement:	L1(a)(i)	Conservation of fuel and power
Comment:		The systems can contribute to satisfying this Requirement. See sections 8 and 10.1 to 10.3 of this Certificate.
Regulation:	7	Materials and workmanship
Comment:		The systems are acceptable. See section 14 and the <i>Installation</i> part of this Certificate.
Regulation:	26	CO₂ emission rates for new buildings
Regulation:	26A	Fabric energy efficiency rates for new dwellings (applicable to England only)
Regulation:	26A	Primary energy consumption rates for new buildings (applicable to Wales only)
Regulation:	26B	Fabric performance values for new dwellings (applicable to Wales only)
Comment:		The (warm roof) systems can contribute to satisfying the requirements of these Regulations. See section 8 of this Certificate.



The Building (Scotland) Regulations 2004 (as amended)

Regulation:	8(1)(2)	Durability, workmanship and fitness of materials
Comment:		The systems can contribute to a construction satisfying the requirements of this Regulation. See sections 13 and 14 and the <i>Installation</i> part of this Certificate.
Regulation:	9	Building standards applicable to construction
Standard:	1.1(a)(b)	Structure
Comment:		The systems have sufficient strength and stiffness to sustain and transmit the design load, with reference to clause 1.1.1 ⁽¹⁾⁽²⁾ of this Standard. See section 6 of this Certificate.
Standard:	2.8	Spread from neighbouring buildings
Comment:		The systems can satisfy this Standard, with reference to clause 2.8.1 ⁽¹⁾⁽²⁾ . See section 11 of this Certificate.
Standard:	3.10	Precipitation
Comment:		The systems can satisfy this Standard, with reference to clause 3.10.1 ⁽¹⁾⁽²⁾ . See section 7 of this Certificate.

Standard:	3.15	Condensation
Comment:		The systems can contribute to minimising risk of surface and interstitial condensation, with reference to clauses 3.15.1 ⁽¹⁾ , 3.15.2 ⁽¹⁾ , 3.15.3 ⁽¹⁾ and 3.15.4 ⁽¹⁾ of this Standard. See sections 9.1 to 9.4 of this Certificate.
Standard:	6.1(b)	Carbon dioxide emissions
Standard:	6.2	Building insulation envelope
Comment:		The systems can contribute to fully or partially satisfying these Standards, with reference to clauses 6.1.1 ⁽¹⁾ , 6.1.2 ⁽¹⁾⁽²⁾ , 6.1.3 ⁽²⁾ , 6.1.6 ⁽¹⁾ , 6.2.1 ⁽¹⁾⁽²⁾ , 6.2.3 ⁽¹⁾ and 6.2.4 ⁽²⁾ . See section 8 of this Certificate. The systems can also contribute to satisfying clauses 6.2.4 ⁽¹⁾ and 6.2.5 ⁽¹⁾⁽²⁾ . See sections 8, 10.1, 10.2 and 10.4 of this Certificate.
Standard:	7.1(a)(b)	Statement of sustainability
Comment:		The systems can contribute to satisfying the relevant requirements of Regulation 9, Standards 1 to 6, and therefore will contribute to a construction meeting a bronze level of sustainability as defined in this Standard. In addition, the systems can contribute to a construction meeting a higher level of sustainability as defined in this Standard, with reference to clauses 7.1.4 ⁽¹⁾⁽²⁾ [Aspects 1 ⁽¹⁾⁽²⁾ and 2 ⁽¹⁾], 7.1.6 ⁽¹⁾⁽²⁾ [Aspects 1 ⁽¹⁾⁽²⁾ and 2 ⁽¹⁾] and 7.1.7 ⁽¹⁾⁽²⁾ [Aspect 1 ⁽¹⁾⁽²⁾]. See section 10.1, 10.2 and 10.4 of this Certificate.
Regulation:	12	Building standards applicable to conversions
Comment:		All comments given for the systems under Regulation 9, Standards 1 to 6, also apply to this Regulation, with reference to clause 0.12.1 ⁽¹⁾⁽²⁾ and Schedule 6 ⁽¹⁾⁽²⁾ .
		(1) Technical Handbook (Domestic). (2) Technical Handbook (Non-Domestic).



The Building Regulations (Northern Ireland) 2012 (as amended)

Regulation:	23(a)(i)	Fitness of materials and workmanship
Comment:	(iii)(b)	The systems are acceptable. See section 14 and the <i>Installation</i> part of this Certificate.
Regulation:	28	Resistance to ground moisture and weather
Comment:		The systems can satisfy the requirements of this Regulation. See section 7 of this Certificate.
Regulation:	29	Condensation
Comment:		The systems can be designed and constructed to satisfy the requirements of this Regulation. See sections 10.1 and 10.3 of this Certificate.
Regulation:	30	Stability
Regulation:	31	Disproportionate collapse
Comment:		The systems have sufficient strength and stiffness to sustain and transmit the design load without excessive deflection or deformation. See section 6 of this Certificate.
Regulation:	36	External fire spread
Comment:		The systems can satisfy the requirements of this Regulation. See sections 11.1, 11.2 and 11.4 of this Certificate.
Regulation:	39	Conservation measures
Comment:		The systems can contribute to satisfying the requirements of this Regulation. See section 8 of this Certificate.
Regulation:	40	Target carbon dioxide emission rate
Comment:		The systems can satisfy the requirements of this Regulation. See sections 8 and 10.1 to 10.3 of this Certificate.

Construction (Design and Management) Regulations 2015 Construction (Design and Management) Regulations (Northern Ireland) 2016

Information in this Certificate may assist the client, designer (including Principal Designer) and contractor (including Principal Contractor) to address their obligations under these Regulations.

See section: 3 *Delivery and site handling* (3.1, 3.4, 3.5 and 3.6) of this Certificate.

Additional Information

NHBC Standards 2018

In the opinion of the BBA, Euroclad Vieo Roof Systems, if installed, used and maintained in accordance with this Certificate, can satisfy or contribute to satisfying the relevant requirements in relation to *NHBC Standards, Part 7 Roofs, Chapters 7.1 Flat roofs and balconies and 7.2 Pitched roofs.*

CE marking

The Certificate holder has taken the responsibility of CE marking the Vieo Roof Sheets [profiled steel (self-supporting) and aluminium (fully supported) roof sheets], in accordance with harmonised European Standard BS EN 14782 : 2006 and BS EN 14783 : 2013, for self-supporting metal roofing applications and fully supported metal roofing applications respectively.

All other components within Elite Guaranteed Systems supplied via Euro Clad Ltd are CE marked by the supplier where required:

- Euroclad RocSlab Insulation — mineral wool to BS EN 13162 : 2012
- Euroclad Vapour Control Layer (VCL) — to BS EN 13984 : 2013.

Technical Specification

1 Description

1.1 Euroclad Vieo Roof Systems comprise Euroclad Vieo Roof Sheets in galvanized steel or aluminium, Euroclad Vieo Sliding Stainless Steel Clips and associated fixings, and can be used as fully supported roof coverings where positive loads are transferred through the sheet to a suitable continuous supporting element, which in turn transfers the loads to the building structure. In addition, Euroclad Vieo Roof Sheets in steel can be used as self-supporting roof coverings with the stainless steel clips and associated fixings where the maximum span is limited to 600 mm. The roof sheets are overlapped on one side and underlapped on the adjacent side, and joined by a Stage 1 (single) seam. Aluminium sheets should be joined by Stages 1 and 2 (double) seam (see Figure 1).

1.2 Euroclad Vieo Roof Systems can be used as weatherproof coverings on cold roofs or insulated warm roofs. Fully supported Euroclad Vieo cold roof weather coverings utilise Euroclad Vieo Roof Sheets, stainless steel clips and associated fixings fixed over a breather membrane on a supporting deck of minimum 18 mm ply (see Figure 2). Self-supporting Vieo cold roof is fixed to battens at maximum 600 mm spans up the roof slope and a breather membrane is incorporated below the sheets (see Figure 5a). This system can be used with insulation as well (see Figure 5b).

1.3 Fully supported warm roof Vieo RocSlab Systems utilise RocBar and RocTube assemblies with supporting RocSlab Insulation and can be used over timber decking (minimum 18 mm ply) or profiled steel decking of minimum thickness 0.7 mm (see Figure 3). Other substrates may be considered to receive the RocTube fixings subject to analysis of the resistance of the fixings to the applied negative wind loads. These constructions employ a VCL on the warm side of the insulation.

1.4 The systems may also be used as weatherproof coverings to the outer skin of structural insulated panels (SIPs), provided they have a minimum facing thickness of 11 mm OSB/3 board which is covered by a breather membrane (see Figure 4).

Figure 1 Euroclad Vio Roof Systems — sheet profile

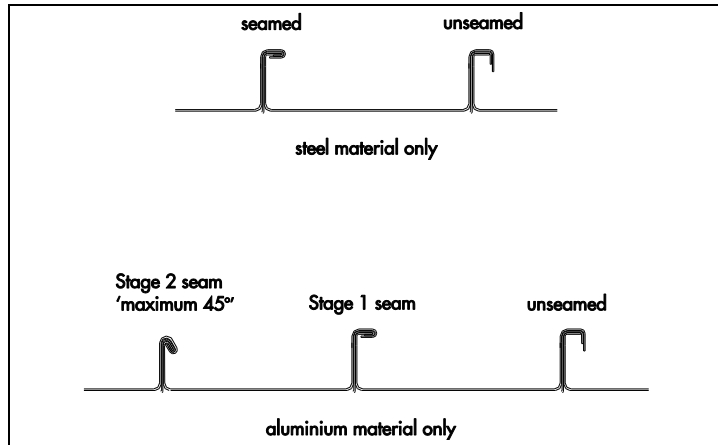

Figure 2 Fully supporting typical cold roof

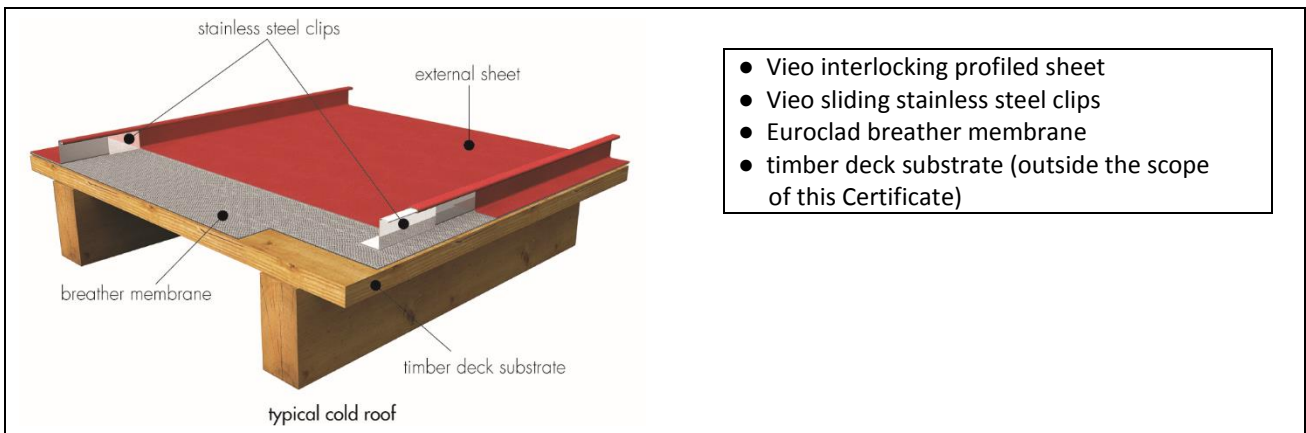

Figure 3 Fully supporting typical RocSlab warm roof

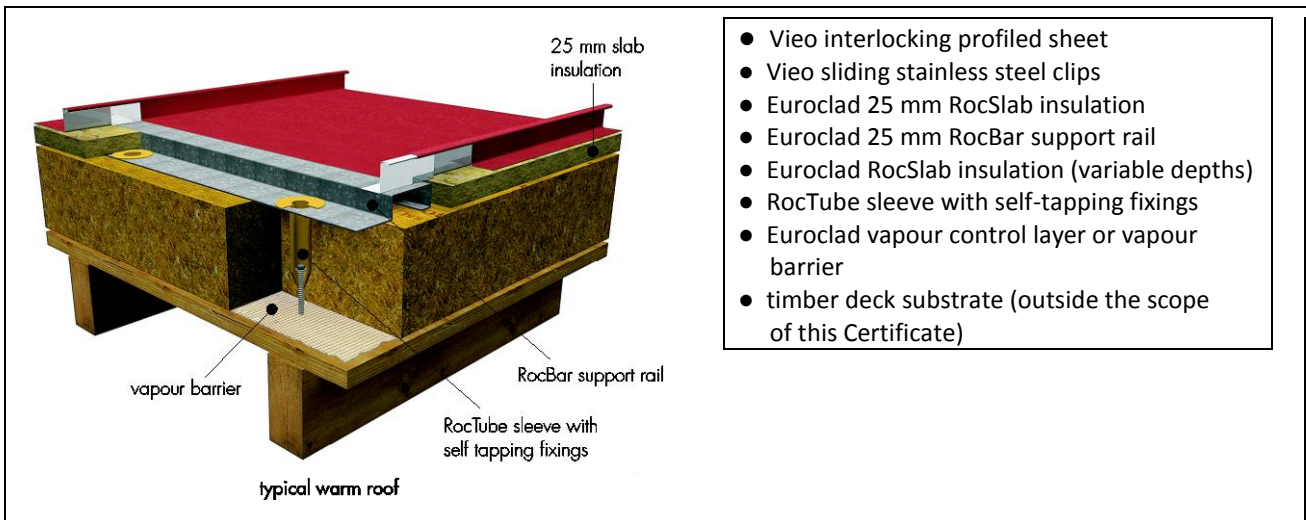

Figure 4 Fully supporting typical roof incorporating SIPs

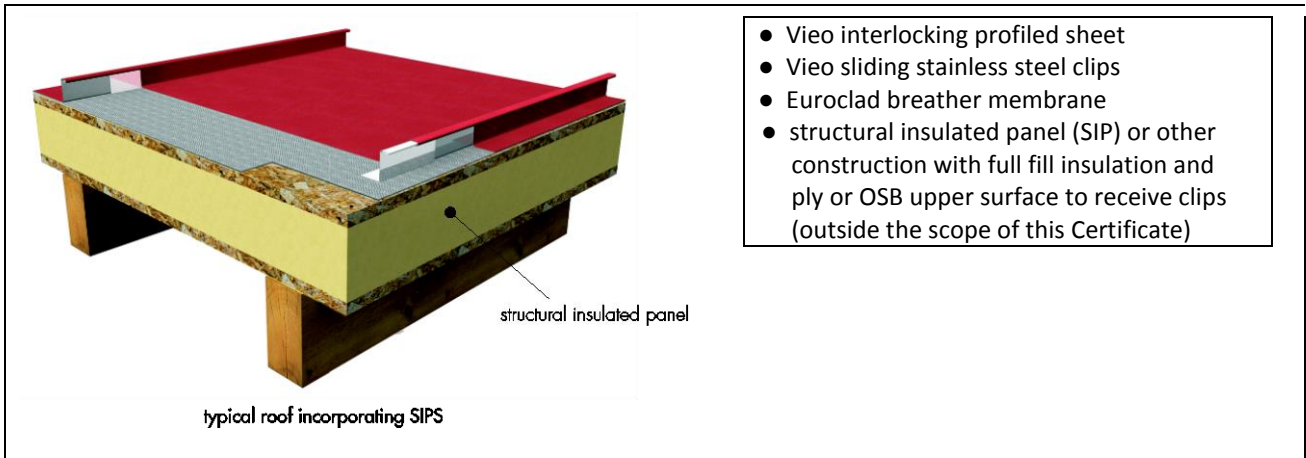
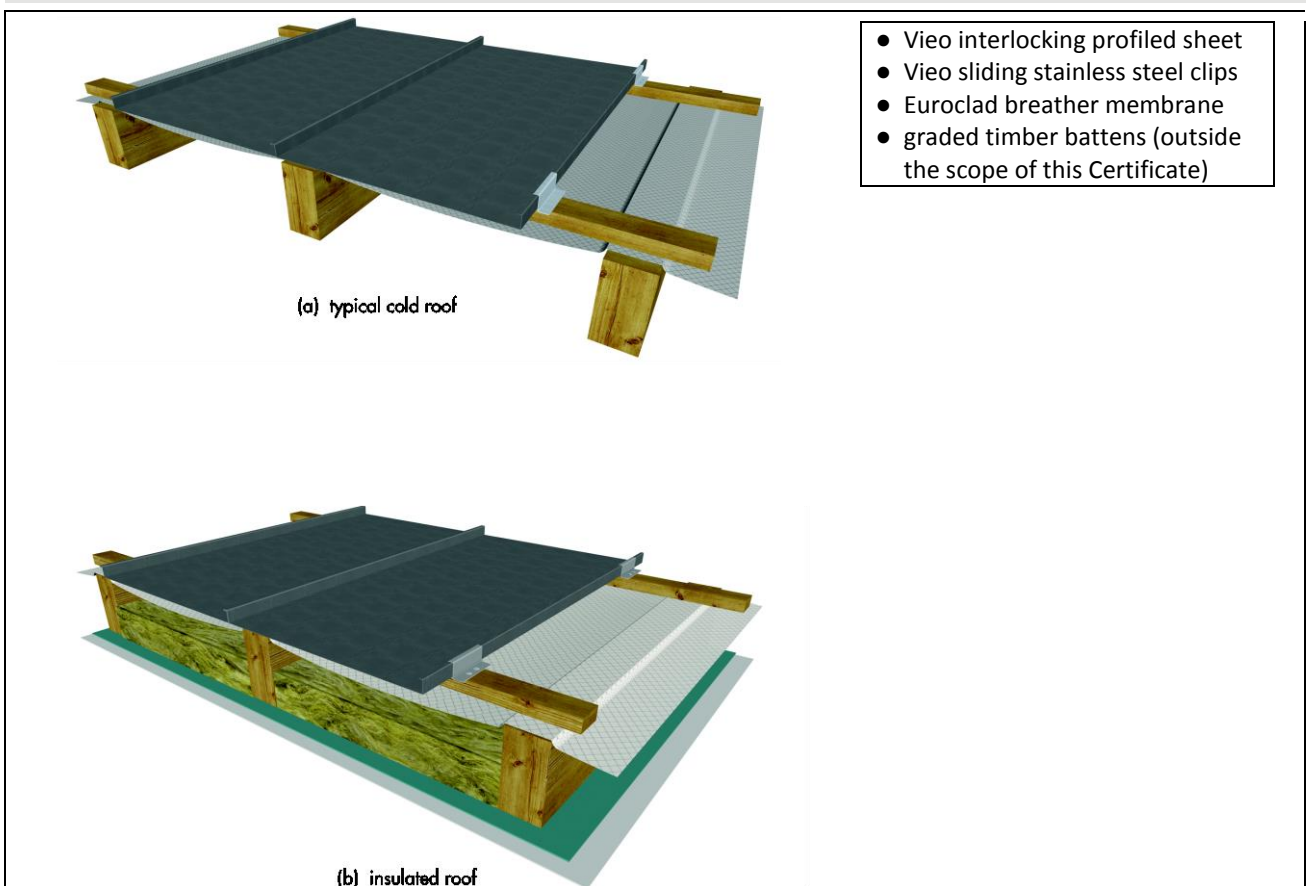

Figure 5 Self-supporting typical cold roof on wooden battens



1.5 The decks and supporting structures on which Euroclad Viero Roof Systems are mounted are outside the scope of this Certificate.

Systems components information

1.6 The systems comprise:

- Euroclad Viero Roof Sheets — interlocking aluminium or galvanized steel sheets (see Figure 6) of nominal overall width of 454 mm and standard lengths up to 20 m, profiled from 0.7 mm thick steel sheet rolled from Tata Steel Colorcoat⁽¹⁾ HPS 200 Ultra, Prisma or LG material, or 0.9 mm thick aluminium alloy sheet to EN AW 3105 in mill finish or with the colour coatings of:
 - Euramax ARS or PVF₂, subject of BBA Certificate 93/2922
 - Hydrocoat PVF₂, subject of BBA Certificate 93/2918

– Arconic Reynolux PVF₂, Duragloss 5000, Polyamide or Polyester subject of BBA Certificate 87/1964
Other coated aluminium materials⁽²⁾, such as Euroclad Vieozinc and longer sheets are available to order but are outside the scope of this Certificate.

- (1) The Colorcoat finishes are produced by Tata UK Limited and are subject of BBA Certificate 91/2717. Bespoke widths with less than 454 mm width are available through consultation with the Certificate holder.
- (2) Whilst the decorative life of these materials is outside the scope of this Certificate, the aluminium substrate would be expected to have an equivalent life to mill finish sheets. For more information, the Certificate holder's advice should be sought.

Figure 6 Euroclad Vieo Roof Systems — sheet profile

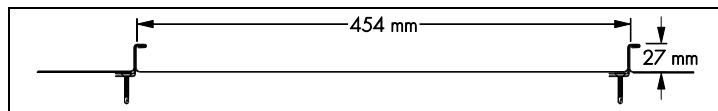

- Euroclad Vieo Sliding Stainless Steel Clips (see Figure 7) are 0.6 mm thick manufactured from stainless steel grade 1.4016 to BS EN 10088-2 : 2014, used for direct fixing of sheets to the timber decking in cold roof constructions or to Euroclad RocBar Support Rails in warm roof constructions. The clips are secured to the deck or Euroclad RocBar Support Rails using two No. JT3-ST2-4.5 x 25 stainless steel Vieo Clip Screws⁽¹⁾

(1) Other fixings may be used provided they demonstrate to have equal or higher pull-out, plate diameter and plate stiffness characteristics.

Figure 7 Euroclad Vieo Sliding Stainless Steel Clips (all dimensions in mm)

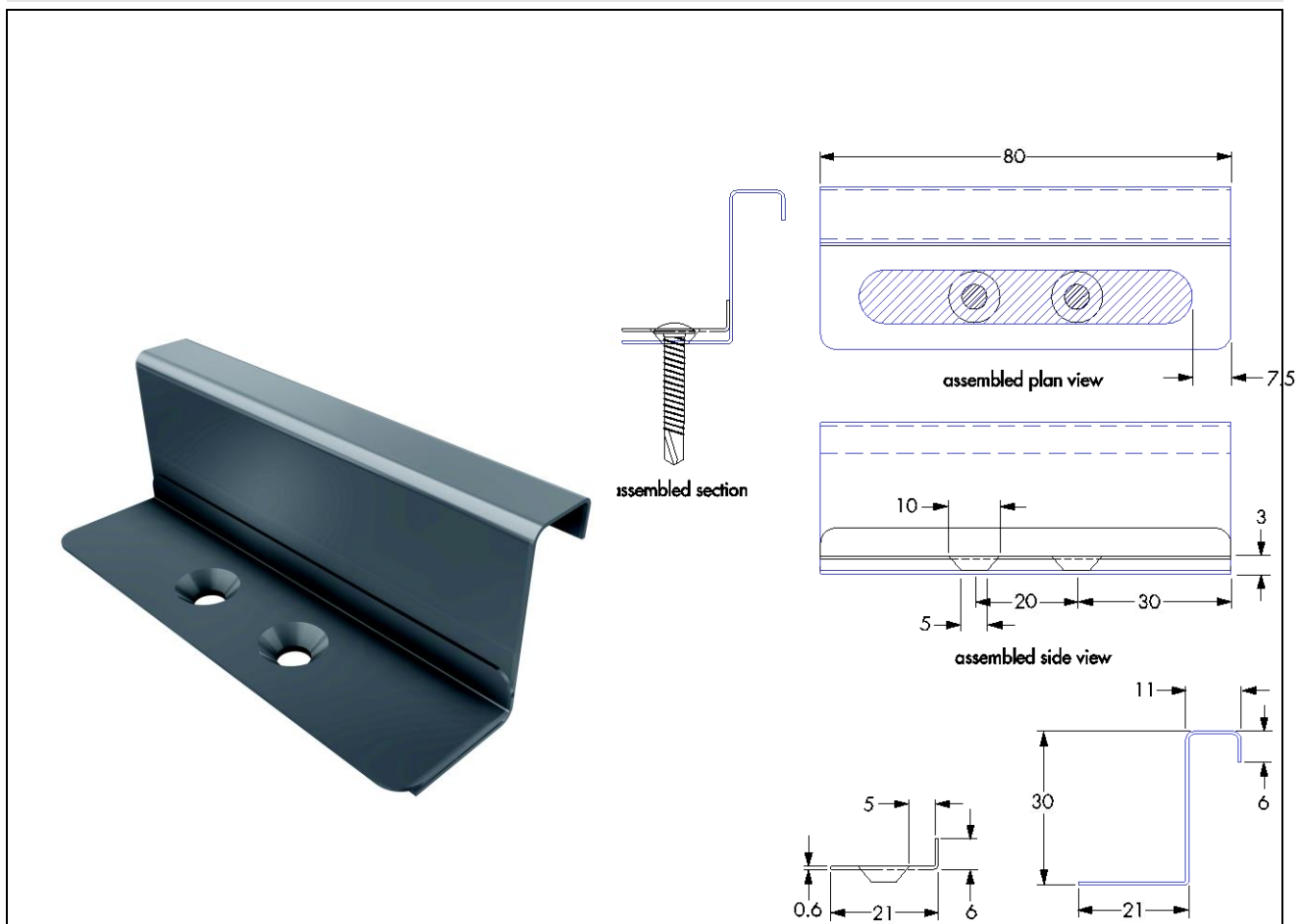

- Euroclad RocBar Support Rails — 25 mm high manufactured from one section of 1.2 mm galvanized steel or two sections of 0.7 mm HPS Ultra or LG coated steel, factory folded and nested to be supplied to site as one section
- Euroclad RocSlab Insulation — mineral wool insulation to BS EN 13162 : 2012 with a λ_D value of $0.037 \text{ W}\cdot\text{m}^{-1}\cdot\text{K}^{-1}$ in thicknesses of 120, 155, 180 and 215 mm and with a λ_D value of $0.034 \text{ W}\cdot\text{m}^{-1}\cdot\text{K}^{-1}$ in 25 mm⁽¹⁾ thickness and minimum density of $105 \text{ kg}\cdot\text{m}^{-3}$

(1) For use between Euroclad RocBar Support Rails.

- Euroclad RocTube — sleeves with carbon steel or stainless steel self-tapping fixings (for use in conjunction with Euroclad RocBar Support Rails) – available in four lengths for through-fixing of 120, 155, 180 or 215 mm Euroclad RocSlab Insulation to the timber deck in warm roof constructions. Other lengths are also available to suit other insulation thicknesses. The fixing method obviates the need for conventional spacers normally employed in warm roof systems
- Euroclad Vapour Control Layer (VCL) (where required):
 - Euroclad Elite VCL — reinforced polyethylene with 500 MN·s·g⁻¹ vapour resistance (minimum)
 - Euroclad Elite VCL — sealing tape, minimum 12 x 1.5 mm
 - Euroclad Elite HH VCL⁽¹⁾ — foil-faced reinforced polyethylene with 30 000 MN·s·g⁻¹ vapour resistance (minimum)
 - Euroclad HH VCL⁽¹⁾ — sealing tape, minimum 12 x 1.5 mm (2 rows)

(1) For use in Class 5 humidity environments.

- breather membrane — Euroclad Elite Roof Breather Membrane or other BBA-approved breather membrane for roofing applications
- Vieo Ridge and Verge Aluminium Closure (see Figure 8) — formed from 1.5 mm extruded aluminium, for use in creating the ridge and verge detailing for the systems. The component allows ridge and verge flashings to be fixed independent of the Euroclad Vieo Roof Sheet.

Figure 8 Vieo Ridge and Verge Aluminium Closure section (all dimensions in mm)

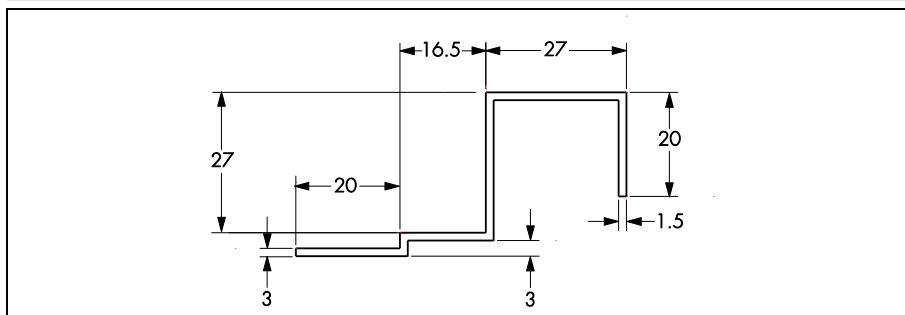

1.7 Ancillary items for use with the systems, but outside the scope of this Certificate, are:

- flashings
- sealants and fillers
- seaming tools and turn up/down tools — motorised and manual hand seaming and turn up/down tools, supplied by the Certificate holder.

1.8 When used in other assemblies not covered by this Certificate, the full system performances given in this Certificate cannot be assumed. The Euroclad Vieo Roof Sheet profile's structural details, fire performance and durability as described in this Certificate will apply, but the designer must be satisfied on other aspects of performance, ie thermal insulation, risk of condensation and acoustic performance, and advice should be sought from the Certificate holder.

2 Manufacture

2.1 Euroclad Vieo Roof Sheets are manufactured from galvanized pre-coated steel coil or coated aluminium, which are rolled to the required length. The sheets may be factory made or rolled onsite using specialist mobile equipment.

2.2 As part of the assessment and ongoing surveillance of product quality, the BBA has:

- agreed with the manufacturer the quality control procedures and product testing to be undertaken
- assessed and agreed the quality control operated over batches of incoming materials
- monitored the production process and verified that it is in accordance with the documented process
- evaluated the process for management of nonconformities
- checked that equipment has been properly tested and calibrated
- undertaken to carry out the above measures on a regular basis through a surveillance process, to verify that the specifications and quality control operated by the manufacturer are being maintained.

2.3 The management system of Euro Clad Ltd has been assessed and registered as meeting the requirements of BS EN ISO 9001 : 2008 by BSI (Certificate Q10647).

2.4 Euroclad Elite Roof Systems are certified to BES 6001 : Issue 3 *Framework Standard for the Responsible Sourcing of Construction Products* by BSI (Certificate BES 637885).

3 Delivery and site handling

3.1 Euroclad Vieo Roof Sheets are normally delivered to site in bundles of up to 20 and in pre-specified lengths according to the dimensions of the roof on which they are to be installed. Delivery is normally by lorry and unloading is carried out by crane or fork lift. A lifting beam with slings should be used for sheets greater than 6 m long. The site must have adequate access and a suitable surface for mobile plant equipment.

3.2 During transit, the sheets must be suitably restrained to prevent abrasion and their edges and corners protected against damage.

3.3 The sheets should be stored on a firm, dry base, with a slight slope to allow drainage, on bearers with a maximum spacing of 900 mm, away from the possibility of damage, and suitably protected. They should be stored as close as possible to the building where they are to be installed.

3.4 The sheets should be handled in accordance with the *Manual Handling Operations Regulations 1992*. The sheets should be lifted from the stack rather than dragged across it.

3.5 When being moved by hand, the sheets should be turned and carried on their edge and care should be taken during handling to avoid damage. Appropriate personal protective equipment should be used.

3.6 Where possible, the sheets should be lifted manually onto the roof individually and this can normally be achieved with sheets up to 6 m in length. Longer sheets may require lifting by mechanical means. If a hoist is required, only suitable slings or ropes should be used, not chains. Care should be taken to avoid distortion through excessive bending.

3.7 The load bearing capacity of the roof structure should be considered where bundles and sheets are laid on the roof in preparation for installation. They must be restrained from sliding down the slope or being moved by wind forces. Sheets should be oriented in the direction in which they will be installed.

3.8 Any damage to components before or during installation will affect the durability of the systems. Items should therefore be handled and stored in accordance with the following guidelines:

- rolls of VCL and breather membranes must be handled carefully to avoid puncturing and to prevent any other damage, and must not be stored on end. For long-term storage the rolls should be protected from ultraviolet light and stored indoors or under non-translucent covers. The VCL should be dry during installation
- Euroclad RocSlab Insulation is delivered to site on pallets protected by polyethylene-wrapped rolls. For long term protection these must be stored indoors or under waterproof protection.

Assessment and Technical Investigations

The following is a summary of the assessment and technical investigations carried out on Euroclad Vieo Roof Systems.

Design Considerations

4 Use

4.1 Euroclad Vieo Roof Systems are satisfactory for use in residential and non-residential buildings as a protective/decorative weatherproof covering over sloping roofs incorporating a continuous timber deck with a minimum finished pitch of 1° and curved installations with a minimum self-curve radius of 20 metres where access is available for maintenance and repair only. The sheets can be factory curved to suit smaller radii roofs and can be produced factory tapered but these are outside the scope of this Certificate (contact the Certificate holder for more information).

4.2 End laps are not normally necessary as the sheets are manufactured in continuous lengths running from eaves to ridge. End laps may only be used on roofs with a pitch greater than 5°. The performance of end lap details is outside the scope of this Certificate.

4.3 On warm roofs, the fixings are supplemented with a standard eaves support angle detail (60 by 60 mm and 1.2 mm thick galvanized steel) which also supports the insulation slab prior to fixing.

4.4 Ridge and eaves details must allow sufficient clearance for thermal expansion and contraction of the sheets.

4.5 If architectural features through fittings or rooflights are required on the roof, special care and attention is necessary to ensure that, in common with all metal roofs, these features have been correctly detailed and fitted. Such items are outside the scope of this Certificate. Further guidance should be sought from the Certificate holder.

5 Practicability of installation

Euroclad Vieo Roof Systems are designed to be installed by a competent general builder or a roofing contractor experienced with these types of systems. The Certificate holder can provide guidance to contractors and assistance in design.

6 Structural performance



6.1 Euroclad Vieo Roof Systems have adequate strength and stiffness to sustain the specified design wind loads in Tables 1 and 2. The designer must ensure that the specified roof construction and the fixings to other structural elements can resist the appropriate positive and negative design load combinations as per BS EN 1990 : 2002 and its UK National Annex.

Table 1 Maximum design wind resistance for fully supported Euroclad Vieo Roof Systems⁽¹⁾⁽²⁾

Maximum Vieo clip/RocBars spacing (mm)	Maximum design wind resistance (Negative) (kN·m ⁻²)
1260	1.5
660	2
300	4

(1) The resistance values are calculated based on characteristic resistance divided by a partial resistance factor of 1.5 based on the mode of failure.

(2) Negative deflection limit = span/90.

Notes:

- the self-weight of the sheets has been taken into account in preparing the data
- for different spans or single spans, excessive loads or spans, different deflection criteria, different factors of safety and different metals, advice should be sought from the Certificate holder.

6.2 For fully supported systems, positive design loads including dead, imposed, wind and snow are limited by the resistance of the supporting roof structure onto which the roof is installed (see Table 1).

6.3 Based on clip spacings, it must be confirmed that the proposed specification is adequate to resist the design loads (see section 6.2).

Table 2 Maximum design wind resistance for self-supported Euroclad Vieo Roof Systems⁽¹⁾⁽²⁾

Maximum Vieo clips/timber battens spacing (mm)	Maximum design wind resistance (Negative) (kN·m ⁻²)	Maximum design wind resistance (Positive) (kN·m ⁻²)
660	2	4
300	4	4

(1) The resistance values are calculated based on characteristic resistance divided by a partial resistance factor of 2.0 based on the mode of failure.

(2) Negative deflection limit = span/90.

Notes:

- the data has been prepared in accordance with BS EN 1990 : 2002 and BS EN 1993-1-3 : 2006 and their respective UK National Annexes
- the self-weight of the sheets has been taken into account in preparing the data
- for single spans, excessive loads or spans, different deflection criteria, different factors of safety and different metals, advice should be sought from the Certificate holder
- it is recommended that the designer should stiffen the self-supporting system to reduce deflection (see footnote 2 of Table 2).

6.4 When evaluating the design loads, the wind loads must be calculated in accordance with the requirements and recommendations of BS EN 1991-1-4 : 2005 and its UK National Annex, and the imposed and snow loads must be determined in accordance with the requirements and recommendations of BS EN 1991-1-1 : 2002 and BS EN 1991-1-3 : 2003 and their UK National Annexes.

6.5 The sheets are capable of withstanding impacts associated with normal handling, installation and service.

7 Weathertightness



7.1 When installed in accordance with the Certificate holder’s instructions, the systems are weathertight when used on roofs with a minimum finished pitch of 1° and curved installations with a minimum self-curve radius of 20 metres and within exposure conditions related to recommended maximum design wind pressures.

7.2 The weathertightness of the systems will not be adversely affected by normal serviceability limit state deflections.

8 Thermal performance



8.1 The thermal performance of each building incorporating the systems must be evaluated in accordance with the relevant national Building Regulations, and is the responsibility of the overall designer of the building.

8.2 Thermal transmittance (U values) for example constructions are given in Table 3, calculated in accordance with BS EN ISO 10211 : 2017. These values have been calculated with RocBar spacer centres of 660 mm and RocTube fixings at 200 mm centres using a λ_D value for the main insulation slab of 0.037 W·m⁻¹·K⁻¹ and for the top (25 mm) slab 0.034 W·m⁻¹·K⁻¹. The values are applicable to constructions over both timber and steel decks. Other U values can be attained with the system using a range of suitable insulation products (see section 6.2). These are outside the scope of this Certificate and advice should be sought from the Certificate holder.

Table 3 U values of Vieo RocSlab warm roof constructions

System height (mm)	RocTube height (mm)	Insulation thickness (mm)	U value (W·m ⁻² ·K ⁻¹)
145	120	120 + 25	0.25
180	155	155 + 25	0.20
205	180	180 + 25	0.18
240	215	215 + 25	0.15

8.3 The effect of thermal bridging at the junctions between the systems and other building elements such as walls, and around openings such as rooflights, must be minimised. The performance of the junction will be dependent on building elements not covered by this Certificate and a suitable assessment of all junction details should be carried out.

8.4 The systems can contribute to maintaining continuity of thermal insulation at junctions between elements and openings. For Accredited Construction Details, the corresponding ψ -values (ψ) in Table 4 of BRE Information Paper IP 1/06 may be used in carbon emission calculations in Scotland and Northern Ireland. Detailed guidance for other junctions and on limiting heat loss by air infiltration can be found in:

England and Wales — Approved Documents to Part L and, for new thermal elements to existing buildings, Accredited Construction Details (version 1.0) (for new-build, see also SAP 2012, Appendix K, and the iSBEM User Manual)

Scotland — Accredited Construction Details (Scotland)

Northern Ireland — Accredited Construction Details (version 1.0).

8.5 Alternatively, to help reduce calculated CO₂ emissions for the whole building values, details provided by the Certificate holder or contained in MCRMA Technical Paper 17 can be used. The Certificate holder provides calculations for ψ -values of details and F factors in accordance with, and software compliant with, the requirements of the national Building Regulations and MCRMA Technical Paper 18.

9 Condensation risk



9.1 In common with all metal roof constructions, there is a risk of condensation which can arise as either interstitial condensation within the roof construction or surface condensation at thermal bridges.

Surface condensation



9.2 The temperature at which surface condensation will occur on the internal surfaces of the roof is dependent on the internal relative humidity, and the internal and external temperatures. The risk of surface condensation and mould growth for a particular construction should be assessed in accordance with BS EN ISO 13788 : 2012. Additional guidance in connection with this can be found in BS 5250 : 2011.

Interstitial condensation



9.3 When used as a warm roof covering, the risk of damage due to interstitial condensation will be minimal.

9.4 When used as a cold roof covering in fully or self-supporting roof systems, the installed breather membrane protects substrates from condensate which may form on the back of the panel. Measures should be taken to minimise water vapour reaching the substrate by incorporating a VCL in the roof construction, providing an adequate seal around ceiling/wall joints and/or ventilating the void under the substrate as appropriate for the construction. The building designer should ensure an appropriate membrane with relevant third-party accreditation is used.

9.5 For buildings in internal humidity class 5 (see Table 4) and in buildings or areas of a building with special internal design conditions, a hygrothermal assessment of the proposed system should be undertaken using the guidance given in BS 5250 : 2011, BS 5925 : 1991 and BS 6229 : 2003, to establish whether special provisions are required.

Table 4 Building internal humidity classes

Humidity class ⁽¹⁾	Building type
1	storage areas
2	offices, shops
3	dwellings with low occupancy
4	dwellings with high occupancy, sports halls, kitchens, canteens, buildings heated with unflued gas heaters
5	special buildings, eg laundries, breweries, swimming pools

(1) As referenced in BS EN ISO 13788 : 2012 and BS 5250 : 2011.

10 Air permeability



10.1 The airtightness of the systems is reliant on the careful sealing of the VCL and other internal details. In addition to sealing at all joints, the VCL must be suitably sealed at the perimeter and all penetrations. Details of sealing at all laps, eaves, ridges, hips, valleys and penetrations must be in accordance with the Certificate holder's instructions.

10.2 The airtightness of the building will also be dependent on the performance of the other building elements. Provided these also incorporate appropriate design details and building techniques, air infiltration through the building fabric should be minimal and the building reasonably airtight.



10.3 Completed buildings are subject to pre-completion testing for airtightness in accordance with the requirements of Approved Documents L1A and L2B (section 20A), Technical Booklet F1 (sections 2.59 to 2.69) and Technical Booklet F2 (sections 2.72 to 2.77).



10.4 Completed dwellings are subject to air permeability testing in accordance with the requirements of Mandatory Standard 6.2 (clause 6.2.5). Alternatively, where a default design value of $15 \text{ m}^3 \cdot \text{m}^{-2} \cdot \text{h}^{-1}$ at 50 Pa is stated by demonstrating compliance under Mandatory Standard 6.1, testing is not required.

10.5 Air leakage design test data are available from the Certificate holder.

11 Performance in relation to fire



11.1 The external sheets have a notional AA designation as defined by BS 476-3 : 2004 and $B_{\text{ROOF}}(t_4)$ in accordance with BS EN 13501-5 : 2016.

11.2 The external sheets have been assessed as Class 0 or 'low risk' as defined in the national Building Regulations.



11.3 In Scotland, the external sheets have a 'low vulnerability' provided the insulation installed has a 'non-combustible' classification when tested in accordance with BS 476-4 : 1970.



11.4 The systems have no minimum boundary restriction and therefore can be used at any distance from the boundary.

12 Acoustic performance

12.1 Test data indicate the sound reduction indices given in Table 5.

Table 5 Sound reduction indices

System	Sound reduction index (dB)
Vieo fully supported 180 mm RocSlab	46 (-2, -7)
Vieo fully supported 240 mm RocSlab	46 (-1, -7)

12.2 Tests to determine rain generated impact sound transmission of the systems in accordance with BS EN ISO 140-18 : 2006 indicate the sound intensity levels given in Table 6.

Table 6 Sound intensity level generated by artificial rainfall

System	LiA (dB·m ⁻²) ⁽¹⁾
Vieo fully supported 180 mm RocSlab	46 (-2, -7)
Vieo fully supported cold roof on 18 mm OSB deck ⁽²⁾	46 (-1, -7)

(1) The sound pressure levels corrected for background noise are converted into sound intensity levels by the laboratory to give the above LiA value.

(2) Tested without any underceiling or insulation at ceiling level.

13 Maintenance



13.1 The systems should be inspected regularly to check for accidental damage to the sheets and their coatings, to ensure that rainware is present and in good order, that flashings are secure and pans are in place and secure, and also for any build-up of dirt and debris. Damage must be repaired and accumulated dirt and debris removed. The frequency of inspections will depend on the environment and use of the building.

13.2 In industrial and coastal areas it may be necessary to clean the installation periodically by hosing with water and a neutral detergent to restore its appearance and to remove corrosive deposits.

13.3 A planned maintenance cycle should be introduced if an extended design life is required. The Certificate holder can recommend a suitable system for maintenance painting.

13.4 Damaged sheets can be removed and replaced. The Certificate holder should be contacted for details.

14 Durability



14.1 The systems are resistant to all normal atmospheric corrosive conditions (including coastal and industrial) and will withstand considerable distortion of the metal without losing adhesion between the coating and the substrate.

14.2 The durability of the sheets will depend upon the coating material, the immediate environment, aspect faced, pitch of roof and use.

14.3 When used in the context of this Certificate, uncoated sheets will have the minimum service life given in section 14.10.

14.4 Maintenance painting may be necessary to restore the appearance of coated sheets or to extend their design life, and should be considered at the intervals given in Table 7.

Table 7 Service life

Sheet material	Minimum service life (years) ⁽¹⁾	
	Rural/suburban	Industrial/coastal
Colorcoat ⁽²⁾ HPS 200 Ultra coated steel	25	20
Colorcoat ⁽²⁾ Prisma coated steel	30	15 ⁽⁶⁾
Colorcoat ⁽²⁾ LG coated steel	25 (CD1 colours) 15 (CD2 colours)	20 (CD1 colours) 10 (CD2 colours)
Euramax PVF ₂ ⁽³⁾ coated aluminium	20	15
Euramax ARS ⁽³⁾ coated aluminium	20	15
Hydrocoat PVF ₂ ⁽⁴⁾ coated aluminium	20	15
Arconic Reynolux Duragloss 5000 ⁽⁵⁾ coated aluminium	15	10

(1) A planned maintenance cycle should consider repainting at the intervals defined, either for aesthetic purposes or to extend the expected life of the coatings.

(2) The Colorcoat finishes are produced by Tata Steel UK Limited and are covered by BBA Certificate 91/2717.

(3) Euramax ARS- and PVF₂-Coated Aluminium Alloy Coil and Sheet are covered by BBA Certificate 93/2922.

(4) Hydrocoat PVF₂-coated Aluminium Alloy Coil and Sheet is covered by BBA Certificate No 93/2918.

(5) Arconic Reynolux Duragloss 5000 coated Aluminium Alloy Coil and Sheet covered by BBA Certificate 87/1964.

14.5 For coated sheets, if the building has an exposed eaves detail and is in an aggressive environment, or is subject to corrosive conditions inside, a more durable specification of the reverse-side coating should be used. Details can be obtained from the Certificate holder.

14.6 Any colour changes to the sheets will be slight and uniform on any one elevation.

14.7 Mortar, render and any other deposits or spillages must be removed from surfaces directly under the sheets prior to laying and should be removed from sheet surfaces following the manufacturers guidance.

14.8 Stucco-finished uncoated aluminium sheets must not come into contact with the following materials:

in any conditions:

- ungalvanized mild steel
- copper and its alloys (including the run-off from copper roofs)
- timber treated with fire retardants
- mortar
- alkali-bearing materials

in damp conditions:

- timber preserved with copper compounds
- other metals (ie bimetallic contact)

in coastal environments:

- lead
- stainless steel

in industrial environments:

- lead.

14.9 Where compatibility problems are likely to occur, barriers such as paints, tapes or pads, appropriate to the materials and environment, should be incorporated.

14.10 Under normal exposure conditions, aluminium sheets do not need painting for corrosion resistance but, if desired, can be painted using conventional techniques for aluminium.

14.11 Roofing constructed with uncoated stucco-finished aluminium sheets will have a minimum service life of

40 years in rural and suburban environments and a minimum of 25 years in more aggressive areas, eg severe industrial or coastal environments.

15 Reuse and recyclability

The systems comprise aluminium and galvanized steel sheets which can be readily recycled. The RocSlab Insulation component may also be recycled. However, detailed advice should be sought from the Certificate holder when considering reuse.

Installation

16 General

16.1 Installation of the Euroclad Vieo Roof Systems is carried out by experienced roofing contractors in accordance with the Certificate holder's instructions. Guidance can be provided by the Certificate holder for contractors who are unfamiliar with the systems.

16.2 The decking of fully supporting constructions and the battens of self-supporting constructions to which the Euroclad Vieo Roof Systems are to be fixed should be structurally sound and constructed in accordance with the requirements of the relevant national Building Regulations and Standards.

16.3 The sheets install to a nominal cover width of 454 mm with a tolerance of ± 2 mm.

16.4 As with all long strip roofing systems, a natural deflection in the pan may occur. The panel will have a tendency to follow the substructure and the surface on which it is installed.

17 Procedure

17.1 Timber decking, battens over suitable structures or SIPs will usually be fitted by others prior to installation of the systems.

17.2 Roof dimensions are checked against the drawings, and for squareness. The ridge, eaves and verge dimensions are similarly checked.

17.3 The construction procedure for fully supported and self-supporting constructions are:

Fully supported

Swarf or debris must be removed from the decking before being covered by the VCL or breather membrane, if required. The VCL or breather membrane is laid over the decking and made continuous by lapping all joints by a minimum of 150 mm. The VCL should be sealed with VCL sealing tape, minimum 12 by 1.5 mm. One strip of VCL sealant tape in the lap is used for standard environments; two strips are used for high humidity environments (Class 4 or 5). The VCL should be continuous over ridges/hips and sealed to penetrations, abutments and perimeters. The breather membrane, if required, should be installed so that it can freely drain to the eaves gutter and should be rolled out from verge to verge, starting at the bottom of the roof slope and overlapping each subsequent roll.

Self-supporting

The Breather membrane should be installed so that it can freely drain to the eaves gutter and should be rolled out from verge to verge, starting at the bottom of the roof slope and overlapping each subsequent roll. Vapour control should be taken into consideration when designing the underlying construction.

17.4 In the case of warm roof construction, the eaves support angle and insulation are laid to the roof and secured using RocBar with RocTube fixings at 200 mm centres. Each lower slab should be secured by a run of RocBar fixings. Slabs should be secured with RocBar progressively, as they are laid, working from the eaves line up. This is to avoid overloading the first tier of fixings and/or support angle with the combined loads of successive slabs and installer traffic.

17.5 The first panel is installed with the overlap rib in line with the roof edge. Clips are fitted to the supporting structure decking, battens or RocBar using two Vieco Clip Screws per clip and the upstand of the panel closed with the seaming tools. The verge closure is lapped over the panel edge and fixed to the supporting structure using fixings at maximum 450 mm centres or to each RocBar.

17.6 The securing clips are pushed over the underlap rib on the opposite side of the panel and secured to the decking, battens or RocBar using two Vieco Clip Screws per clip.

17.7 The overlap of the next panel is inserted over the underlap of the first panel and the pan of the panel laid flat on the decking, battens or RocBar, or supporting insulation. Seaming tools are then rolled along the underlap/overlap, folding the two together with the underlying clips and locking the sheets in place.

17.8 Subsequent sheets are laid in a similar manner as described in 17.7.

17.9 Once the penultimate panel has been installed, the end panel can be fitted to suit the roof edge, and verge detail completed.

17.10 To ensure good weathertightness and efficient rainwater run-off, all components, such as edge details and sealants, should be used in accordance with the Certificate holder's specifications and manufacturer's instructions.

17.11 A turn up/turn down tool is used to bend the pan of the profile upwards at the ridge and downwards at the eaves. More detailed installation instructions are available from the Certificate holder.

Technical Investigations

18 Tests

Tests were carried out on the systems and the results assessed to determine:

- resistance to dead and imposed (snow) loading
- resistance to wind loading
- behaviour of fixings and profile under static and cyclic loading
- resistance to impact
- behaviour under concentrated loads
- acoustic performance.

19 Investigations

19.1 The manufacturing process was evaluated, including the methods adopted for quality control, and details were obtained of the quality and compositions of the materials used.

19.2 The Certificate holder's technical literature was examined for any inconsistencies and general content.

19.3 An assessment was made of:

- fire resistance
- practicability of installation
- condensation risk and thermal transmittance
- weathertightness of fixed cladding and details
- acoustic performance.

19.4 Existing information relating to the durability of the systems, performance in fire and compatibility of materials in contact, was examined.

19.5 A visit was made to a site to assess the practicability of installation.

Bibliography

- BRE Information Paper IP 1/06 *Assessing the effects of thermal bridging at junctions and around openings*
- BS 476-3 : 2004 *Fire tests on building materials and structures — Classification and method of test for external fire exposure to roofs*
- BS 476-4 : 1970 *Fire tests on building materials and structures — Non-combustibility test for materials*
- BS 5250 : 2011 + A1 : 2016 *Code of practice for condensation in buildings*
- BS 5925 : 1991 *Code of practice for ventilation principles and designing for natural ventilation*
- BS 6229 : 2003 *Flat roofs with continuously supported coverings — Code of practice*
- BS EN 1990 : 2002 + A1 : 2005 *Eurocode — Basis of structural design*
NA to BS EN 1990 : 2002 + A1 : 2005 UK National Annex to *Eurocode — Basis of structural design*
- BS EN 1991-1-1 : 2002 *Eurocode 1 — Actions on structures — General actions — Densities, self-weight, imposed loads for buildings*
NA to BS EN 1991-1-1 : 2002 UK National Annex to *Eurocode 1 — Actions on structures — General actions — Densities, self-weight, imposed loads for buildings*
- BS EN 1991-1-3 : 2003 + A1 : 2015 *Eurocode 1 — Actions on structures — General actions — Snow loads*
NA + A1 : 15 to BS EN 1991-1-3 : 2003 + A1 : 2015 UK National Annex to *Eurocode 1 — Actions on structures — General actions — Snow loads*
- BS EN 1991-1-4 : 2005 + A1 : 2010 *Eurocode 1 — Actions on structures — General actions — Wind actions*
NA to BS EN 1991-1-4 : 2005 + A1 : 2010 UK National Annex to *Eurocode 1 — Actions on structures — General actions — Wind actions*
- BS EN 1993-1-3 : 2006 *Eurocode 3 — Design of steel structures — General rules*
NA to BS EN 1993-1-3 UK National Annex to *Eurocode 3 — Design of steel structures — General rules*
- BS EN 10088-2 : 2014 *Stainless steels — Technical delivery conditions for sheet/plate and strip of corrosion resisting steels for general purposes*
- BS EN 13162 : 2012 + A1 : 2015 *Thermal insulation products for buildings — Factory made mineral wool (MW) products — Specification*
- BE EN 13501-5 : 2016 *Fire classification of construction products and building elements — Classification using data from external fire exposure to roof tests*
- BS EN 13984 : 2013 *Flexible sheets for waterproofing — Plastic and rubber vapour control layers — Definitions and characteristics*
- BS EN 14782 : 2006 *Self-supporting metal sheet for roofing, external cladding and internal lining — Product specification and requirements*
- BS EN 14783 : 2013 *Fully supported metal sheet and strip for roofing, external cladding and internal lining — Product specification and requirements*
- BS EN ISO 140-18 : 2006 *Acoustics — Measurement of sound insulation in buildings and of building elements — Laboratory measurement of sound generated by rainfall on building elements*
- BS EN ISO 9001 : 2008 *Quality management systems — Requirements*
- BS EN ISO 10211 : 2017 *Thermal bridges in building construction — Heat flows and surface temperatures. Detailed calculations*
- BS EN ISO 13788 : 2012 *Hygrothermal performance of building components and building elements — Internal surface temperature to avoid critical surface humidity and interstitial condensation — Calculation methods*
- MCRMA Technical Paper 17 *Design guide for metal roofing and cladding to comply with energy requirements of the UK Building Regulations (2006)*
- MCRMA Technical Paper 18 *Conventions for calculating U-values, F-values and ψ -values for metal cladding systems using two- and three- dimensional thermal calculations*

20 Conditions

20.1 This Certificate:

- relates only to the product/system that is named and described on the front page
- is issued only to the company, firm, organisation or person named on the front page – no other company, firm, organisation or person may hold claim that this Certificate has been issued to them
- is valid only within the UK
- has to be read, considered and used as a whole document – it may be misleading and will be incomplete to be selective
- is copyright of the BBA
- is subject to English Law.

20.2 Publications, documents, specifications, legislation, regulations, standards and the like referenced in this Certificate are those that were current and/or deemed relevant by the BBA at the date of issue or reissue of this Certificate.

20.3 This Certificate will remain valid for an unlimited period provided that the product/system and its manufacture and/or fabrication, including all related and relevant parts and processes thereof:

- are maintained at or above the levels which have been assessed and found to be satisfactory by the BBA
- continue to be checked as and when deemed appropriate by the BBA under arrangements that it will determine
- are reviewed by the BBA as and when it considers appropriate.

20.4 The BBA has used due skill, care and diligence in preparing this Certificate, but no warranty is provided.

20.5 In issuing this Certificate the BBA is not responsible and is excluded from any liability to any company, firm, organisation or person, for any matters arising directly or indirectly from:

- the presence or absence of any patent, intellectual property or similar rights subsisting in the product/system or any other product/system
- the right of the Certificate holder to manufacture, supply, install, maintain or market the product/system
- actual installations of the product/system, including their nature, design, methods, performance, workmanship and maintenance
- any works and constructions in which the product/system is installed, including their nature, design, methods, performance, workmanship and maintenance
- any loss or damage, including personal injury, howsoever caused by the product/system, including its manufacture, supply, installation, use, maintenance and removal
- any claims by the manufacturer relating to CE marking.

20.6 Any information relating to the manufacture, supply, installation, use, maintenance and removal of this product/system which is contained or referred to in this Certificate is the minimum required to be met when the product/system is manufactured, supplied, installed, used, maintained and removed. It does not purport in any way to restate the requirements of the Health and Safety at Work etc. Act 1974, or of any other statutory, common law or other duty which may exist at the date of issue or reissue of this Certificate; nor is conformity with such information to be taken as satisfying the requirements of the 1974 Act or of any statutory, common law or other duty of care.